



**MICRO SWITCH
EV SERIES**



FEATURES

- High applicability for general industrial equipment and home appliances
- High precision mechanism design offering durable acute operation and long life
- Heavy/Light operation force specifications
- Three Kinds of terminal available #187 quick connect/solder, #187 quick connect and #250 quick connect type
- RoHS Compliant

APPLICATIONS

- Home appliances
- Vending machines
- Amusement and communication equipment
- Office automation appliances
- General industrial machines

SPECIFICATIONS

1. ELECTRICAL

DESCRIPTION		TYPE	EV-11	EV-16	EV-21
Contact Rating:	AC 125V		11A 1/2HP	16A 1/2HP	21A 1/2HP
	AC 250V		11A 1/2HP	16A 1/2HP	21A 1/2HP
	DC 125V		0.6A	0.6A	0.6A
	DC 250V		0.3A	0.3A	0.3A
Contact Resistance: (Initial)			50mΩ Max.		
Insulation Resistance			100 MΩ Min. at 500 VDC		





2. CHARACTERISTICS

DESCRIPTION		TYPE	EV-11	EV-16	EV-21
Mechanical Life (Cycles Operations)			50,000,000		
Electrical Life (Cycles Operations)			300,000	100,000	100,000
Ambient Temperature			-25°C to +80°C (without dew condensation)		
Ambient Humidity			Max. 85% RH		
Max. operating cycle rate	Mechanical		600 cycle/min.		
	Electrical		60 cycle/min.		
Allowable Operation speed			0.1 to 1,000 mm/sec (without lever)		
Dielectric Strength	Between non-continuous terminal		AC 1000Vrms		
	Between each terminal and other exposed metal parts		AC 2000Vrms		
	Between each terminal and ground		AC 2000Vrms		
Vibration Resistance (Without lever)			10 to 55 Hz amplitude of 1.5mm		
Shock Resistance (Without lever)			200m/s ² {20G}Min.	300m/s ² {30G}Min.	300m/s ² {30G}Min.
Unit weight			Approx 6.5g		

■ PART NUMBERING SYSTEM

EV - XX X X X X XX

XX: Special product number

Operation force: (Without lever)

- 1: 100 gf (EV11)
- 2: 200 gf (EV11, EV16)
- 3: 400 gf (EV11, EV16, EV21)

Actuator type:

- 0: Without lever
- 1: Short straight lever
- 2: Straight lever
- 3: Long straight lever
- 4: Simulated roller lever
- 5: Short roller lever
- 6: Roller lever

Terminal type:

- 1: #187 Quick connect/solder terminal (EV11, EV16)
- 2: #187 Quick connect terminal (EV11)
- 3: #250 Quick connect terminal (EV11, EV16, EV21)

Contact arrangement:

- 1: Bottom COM, SPST-NO (1a)
- 2: Bottom COM, SPST-NC (1b)
- 3: Bottom COM, SPDT (1c)
- 4: Side COM, SPST-NO (1a)
- 5: Side COM, SPST-NC (1b)
- 6: Side COM, SPDT (1c)

Rating current:

- 11: 11 Ampere
- 16: 16 Ampere
- 21: 21 Ampere

Series name:

EV: V type micro switch

Actuators

0	Without lever	
1	Short straight lever	
2	Straight lever	
3	Long straight lever	
4	Simulated roller lever	
5	Short roller lever	
6	Roller lever	

Terminal type

1	#187 Quick connect/solder terminal	
2	#187 Quick connect terminal	
3	#250 Quick connect terminal	

■ CIRCUIT DIMENSIONS UNIT:mm(inch)

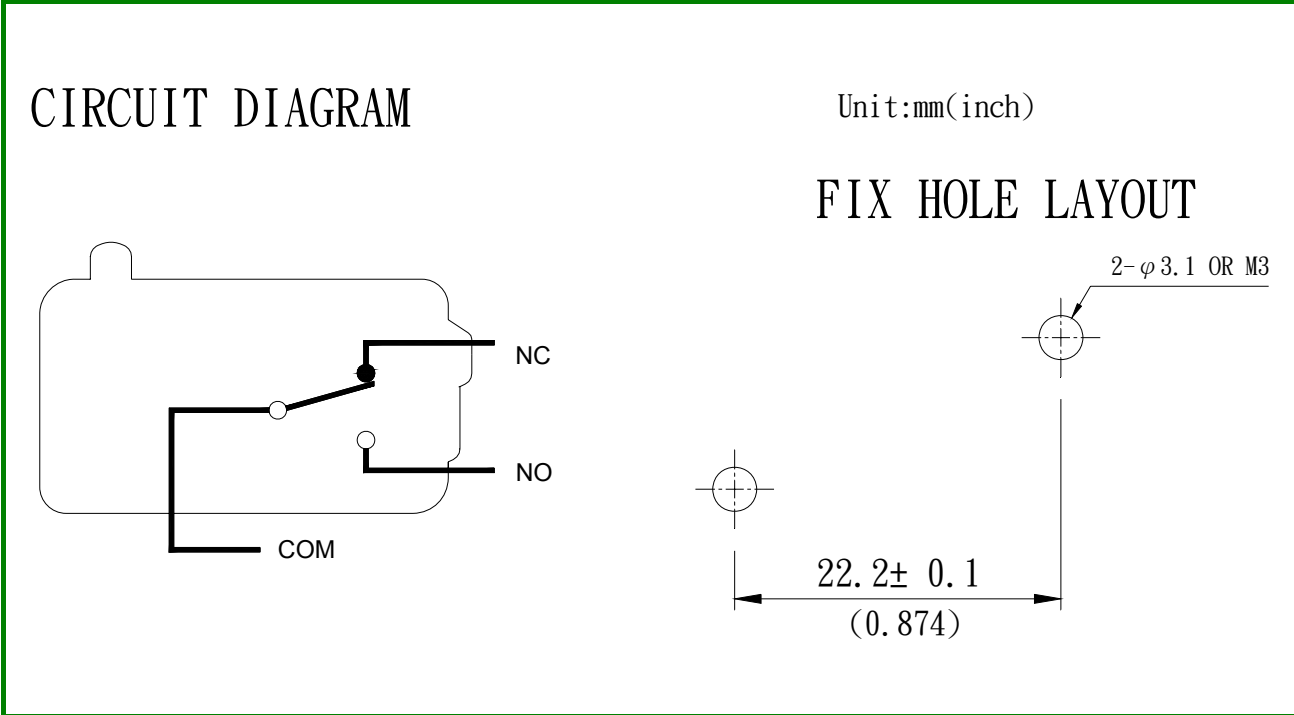

■ DIMENSIONS UNIT:mm(inch)

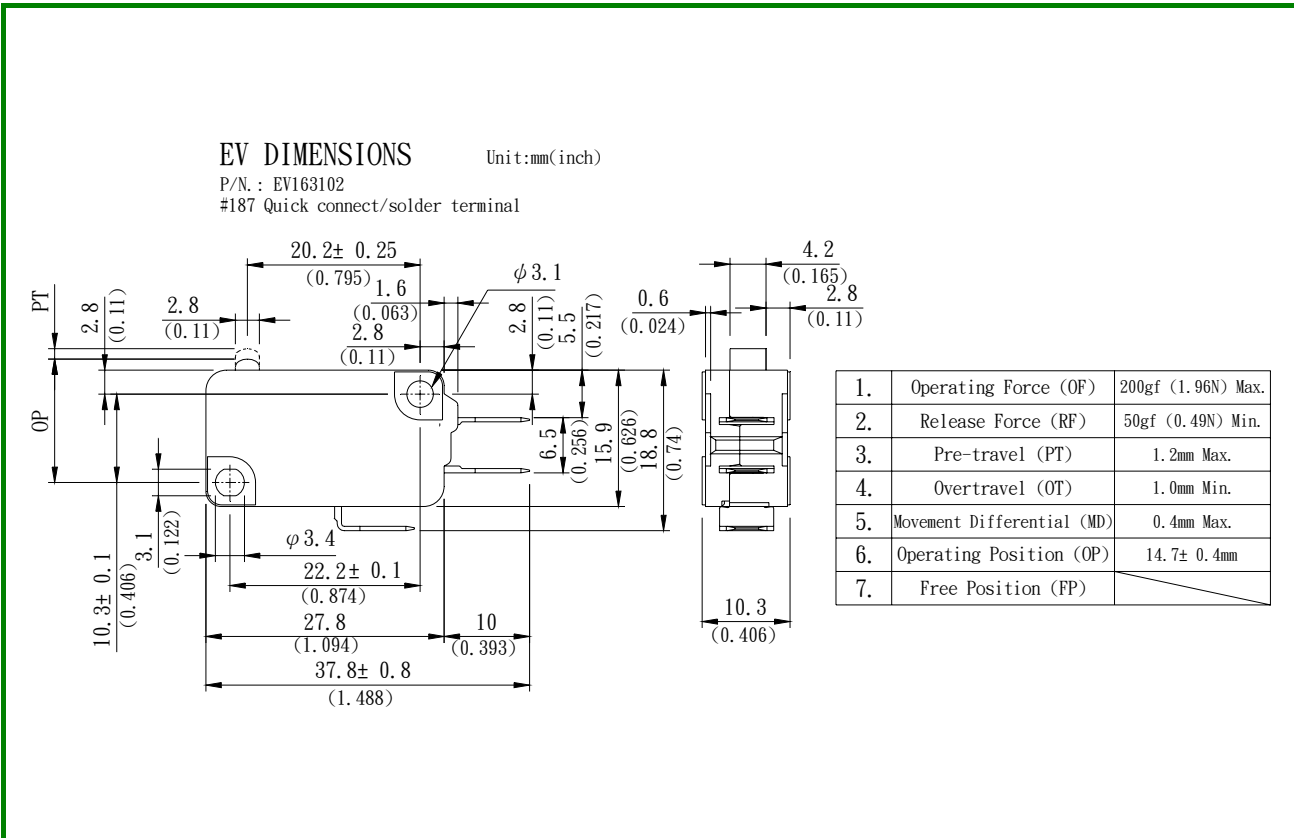

EV DIMENSIONS

Unit:mm(inch)

P/N. : EV163112

#187 Quick connect/solder terminal

Short straight lever

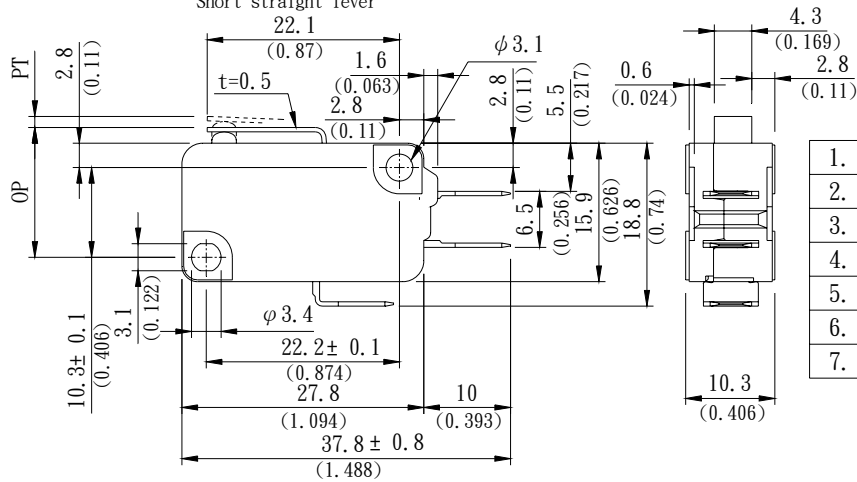

1.	Operating Force (OF)	200gf (1.96N) Max.
2.	Release Force (RF)	50gf (0.49N) Min.
3.	Pre-travel (PT)	1.6mm Max.
4.	Overtravel (OT)	0.8mm Min.
5.	Movement Differential (MD)	0.6mm Max.
6.	Operating Position (OP)	15.2 ± 0.5mm
7.	Free Position (FP)	

EV DIMENSIONS

Unit:mm(inch)

P/N. : EV163122

#187 Quick connect/solder terminal

Straight lever

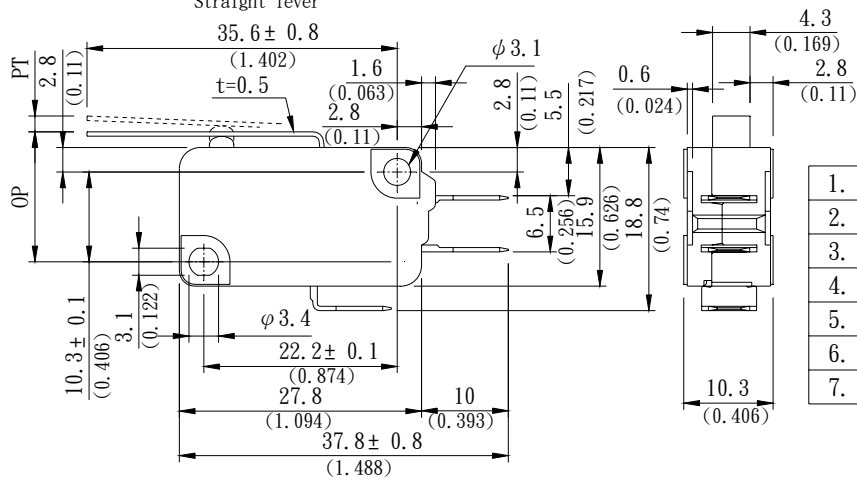

1.	Operating Force (OF)	125gf (1.23N) Max.
2.	Release Force (RF)	14gf (0.14N) Min.
3.	Pre-travel (PT)	4.0mm Max.
4.	Overtravel (OT)	1.6mm Min.
5.	Movement Differential (MD)	1.5mm Max.
6.	Operating Position (OP)	15.2 ± 1.2mm
7.	Free Position (FP)	



Switch

EV DIMENSIONS

Unit:mm(inch)

P/N.: EV163132
#187 Quick connect/solder terminal
Long straight lever

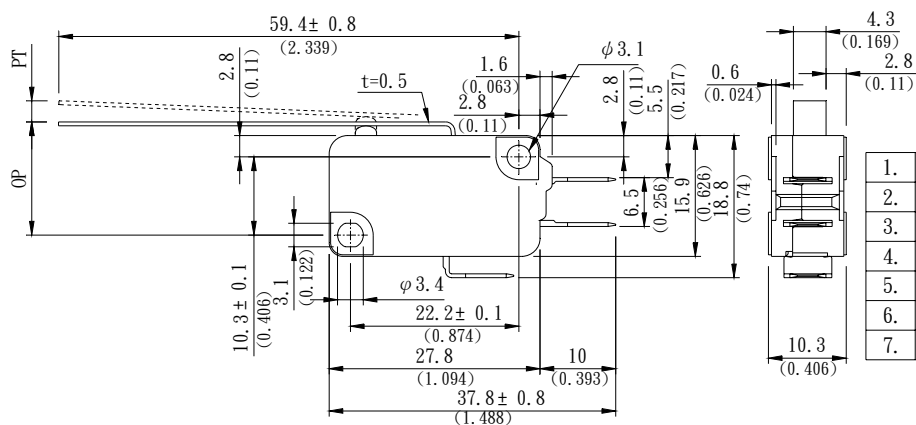

1.	Operating Force (OF)	70gf (0.69 N) Max.
2.	Release Force (RF)	6gf (0.06N) Min.
3.	Pre-travel (PT)	9.0mm Max.
4.	Overtravel (OT)	2.0mm Min.
5.	Movement Differential (MD)	2.8mm Max.
6.	Operating Position (OP)	15.2 ^{+2.6} _{-3.2} mm
7.	Free Position (FP)	

EV DIMENSIONS

Unit:mm(inch)

P/N.: EV163142
#187 Quick connect/solder terminal
Simulated roller lever

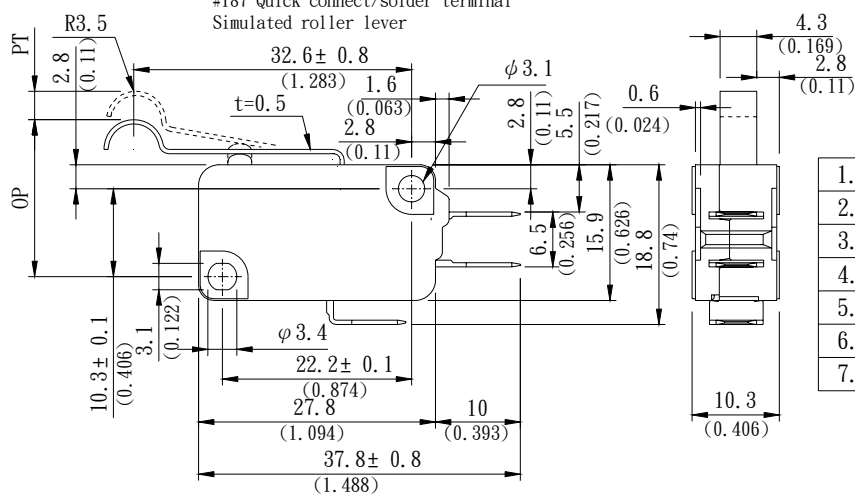

1.	Operating Force (OF)	125gf (1.23N) Max.
2.	Release Force (RF)	14gf (0.14N) Min.
3.	Pre-travel (PT)	4.0mm Max.
4.	Overtravel (OT)	1.6mm Min.
5.	Movement Differential (MD)	1.5mm Max.
6.	Operating Position (OP)	18.7 ± 1.2mm
7.	Free Position (FP)	

EV DIMENSIONS

Unit:mm(inch)

P/N : EV163152

#187 Quick connect/solder terminal

Short roller lever

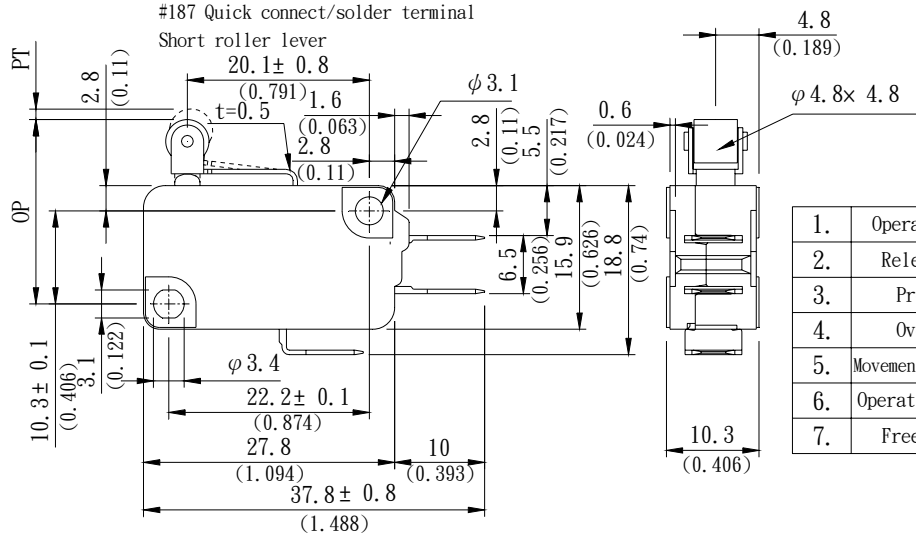

1.	Operating Force (OF)	240gf (2.35N) Max.
2.	Release Force (RF)	50gf (0.49N) Min.
3.	Pre-travel (PT)	1.6mm Max.
4.	Overtravel (OT)	0.8mm Min.
5.	Movement Differential (MD)	0.6mm Max.
6.	Operating Position (OP)	20.7 ± 0.6mm
7.	Free Position (FP)	

EV DIMENSIONS

Unit:mm(inch)

P/N : EV163162

#187 Quick connect/solder terminal

Long roller lever

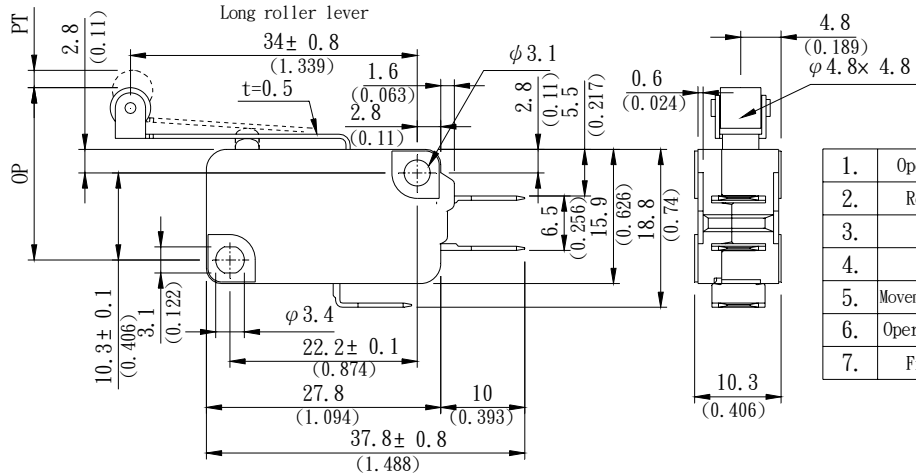

1.	Operating Force (OF)	125gf (1.23N) Max.
2.	Release Force (RF)	14gf (0.14N) Min.
3.	Pre-travel (PT)	4.0mm Max.
4.	Overtravel (OT)	1.6mm Min.
5.	Movement Differential (MD)	1.5mm Max.
6.	Operating Position (OP)	20.7 ± 1.2mm
7.	Free Position (FP)	